

The **MOD-0STB-03K Strobe Alarm Module** provides an improved strobe alarm for FG-3000(B) and FG-2000(B) systems. This module can distinguish day flashes from night flashes and generates an alarm when the lighting system flashes at the wrong intensity level. An internal timer generates an alarm if the photocell fails to transition during a 24 hour period. One Form-C dry-contact relay is provided for indication of alarm. A multi-color LED gives visual indication of alarm status.



Alarm LED	
Red	= Strobe Alarm
Blinking Red	= PEC Alarm
Green	= No Alarm
OFF	= No Power

**Note: Always de-energize the lighting system before installation or servicing.**

### Installation & Setup

- 1) Select **FG-2000(B)** or **FG-3000(B)** according to type of system.
- 2) Select **NON B-SERIES** or **B-SERIES** according to type of system
- 3) Select **NO B.U. ALARM** if you do not wish to alarm in white backup mode (FG-3000(B) only).
- 4) Route the flash head anode wire (red) through the current transformer as shown below.
- 5) Wire Input power (L1, N), Photocell (PEC) and Alarm Connections (N.C., N.O., COM).
- 6) Use the **photocell** to operate the system in Day and Night mode and verify no alarms are generated. Using the manual override switches will cause an alarm in one mode.

FG-2000(B)	<input type="checkbox"/>	4	FG-3000(B)
NON B-SERIES	<input type="checkbox"/>	3	B-SERIES
NO B.U. ALARM	<input type="checkbox"/>	2	
	<input type="checkbox"/>	1	

#### TYPICAL INSTALLATION WIRING DIAGRAM

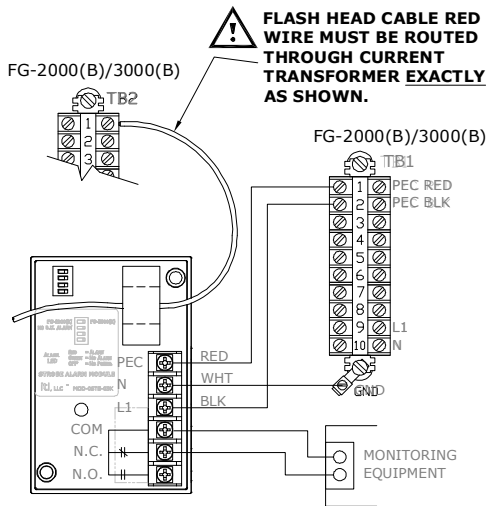

#### DIMENSIONS & WIRING FOR INPUT POWER AND ALARM CONTACT

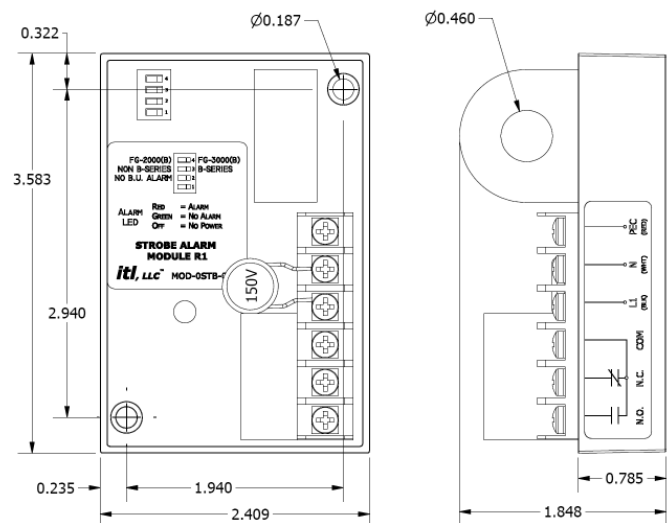

## Trouble Shooting

Always de-energize the lighting system at the circuit breaker panel before installation, trouble shooting or servicing. Only properly trained personnel should attempt to install, trouble shoot or service this equipment.

Always use the **Photocell** to change modes when testing an installed MOD-OSTB-03K. Using the manual override switches will always produce an alarm in one mode.

The MOD-OSTB-03K is not a side light alarm module. This module does not replace any component in the lighting system. It is designed to be added to the lighting system.

### Anode Wire Routing

If the MOD-OSTB-03K module produces an alarm in both Day mode and Night mode (always use the **photocell** to select the mode) then verify that the red Anode wire is routed exactly as shown on the wiring diagram. The anode wire must be run through the current transformer in the direction indicated.

### Capacitors

If the MOD-OSTB-03K module produces an alarm in only one mode (always use the **photocell** to select the mode) then test the appropriate capacitor(s). For day mode alarms test all capacitors in the day mode capacitor bank. For night mode test the night mode capacitor. Testing capacitors requires a meter capable of measuring capacitance such as the Fluke 179. The lighting system must be completely de-energized and all capacitors fully discharged before measuring capacitors. The capacitor must be disconnected from the lighting system wiring for correct capacitance measurement. If testing the capacitor(s) is not possible then replacing the capacitor(s) can be tried. Test or replace only one capacitor at a time to avoid wiring mistakes.

### Flash Head

It is possible for a failure of components in the flash head (flash tube or trigger transformer) to cause sustained and/or intermittent alarms on the MOD-OSTB-03K. Generally the alarm will be produced in only one mode (always use the **photocell** to select the mode).

**FG-3000B** systems have two trigger wires in the flash head cable (black and blue). These wires can be swapped (FG-3000B system **ONLY**) to test whether the alarm changes modes. If the alarm changes to the opposite mode after swapping the trigger wires then the problem is in the flash head. If the alarm stays in the same mode then the problem is in the power supply cabinet.

**FG-3000** systems have only one trigger wire in the flash head cable. A similar test can be performed by moving the black wire on the motherboard K3 relay from the NO to the NC position.

The lighting system must be completely de-energized and all capacitors fully discharged before attempting this procedure.

### Before leaving the site:

- Return all wires to their original positions.
- Verify that the system flashes the correct color in each mode using the photocell.
- Verify that no alarms are produced in each mode using the photocell.